



UN200-6D (6V200Ah/10hr)

The rechargeable batteries are lead-lead dioxide systems. The dilute sulfuric acid electrolyte is absorbed by separators and thus immobilized.



Should the battery be accidentally overcharged producing hydrogen and oxygen, Special one-way valves allow the gases to escape thus avoiding excessive pressure build-up. Otherwise, the battery is completely sealed and is, therefore, maintenance-free, leak proof and usable in any position.

Battery Construction

Component	Positive plate	Negative plate	Container	Cover	Safety valve	Terminal	Separator	Electrolyte
Raw material	Lead dioxide	Lead	ABS	ABS	Rubber	Copper	Fiberglass	Sulfuric acid

General Feature

- Absorbent Glass Mat(AGM) technology for efficient gas recombination of up to 99% and freedom from electrolyte maintenance or water adding.
- Not restricted for air transport-complies with IATA/ICAO Special Provision A67.
- UL-recognized component.
- Can be mounted in any orientation.
- Computer designed lead, calcium tin alloy grid for high power density.
- Long service life, float or cyclic applications.
- Maintenance-free operation.
- Low self discharge.

Performance Characteristics

Capacity 77°F(25°C)	20 hour rate (10.4A、5.4V)	208Ah
	10 hour rate (20A、5.4V)	200Ah
	5 hour rate (35 A、5.25V)	175Ah
	1 hour rate (130A、4.8V)	130Ah
Internal Resistance	Full charged Battery77°F(25°C): 4mΩ	
Capacity affected by Temperature (10 hour rate)	104° F(40°C)	102%
	77° F(25°C)	100%
	32° F(10°C)	85%
	5° F(-15°C)	65%
Self-Discharge 68°F(20°C)	Capacity after 3 month storage	90%
	Capacity after 6 month storage	80%
	Capacity after 12month storage	60%
Max. discharge current77°F(25°C): 1000A(5S)		
Charge (Constant Voltage)	Float: 6.8~6.9 V/77° F(25°C)	
	Cycle:7.25~7.45 V/77°F(25°C) Max. Current: 50A	

SPECIFICATION

Nominal voltage 6V
Number of cell 3
Length(mm/inch) 306/12.1
Width(mm/inch) 168/6.61
Height(mm/inch) 220/8.66
Total Height(mm/inch) 226/8.90
Approx. Weight(kg/lbs) 28.3/62.4

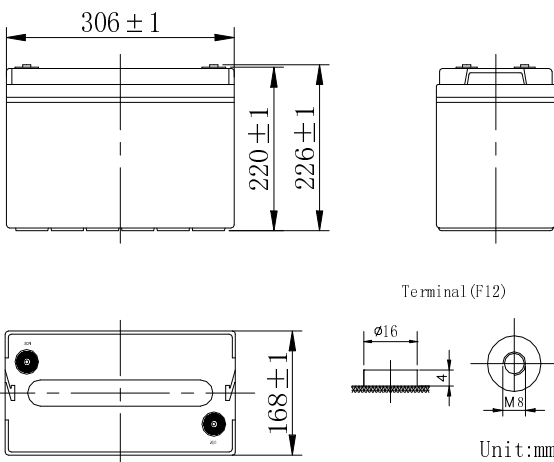

Discharge Constant Current (Amperes at 77° F 25 °C)

End Point Volts/Cell	5min	10min	15min	30min	1h	3h	5h	10h	20h
1.60V	525	435	345	215	130	53.8	36.5	20.5	10.7
1.65V	490	410	325	207	127	52.9	36.0	20.4	10.7
1.70V	455	385	305	199	124	52.0	35.5	20.3	10.6
1.75V	420	358	285	191	121	51.1	35.0	20.2	10.5
1.80V	370	328	263	181	117	50.0	34.4	20.0	10.4

Discharge Constant Power (watts at 77° F 25 °C)

End Point Volts/Cell	5min	10min	15min	30min	45min	1h	2h	3h	5h
1.60V	865	715	578	378	271	250	137	97.9	70.7
1.65V	819	680	559	364	265	245	135	96.6	70.1
1.70V	773	644	541	350	260	241	132	95.3	69.5
1.75V	727	606	523	336	254	236	129	93.9	69.0
1.80V	679	576	492	322	249	231	125	92.9	68.4

(Note)The above characteristics data are average values obtained Within three charge/discharge cycles not the minimum values.

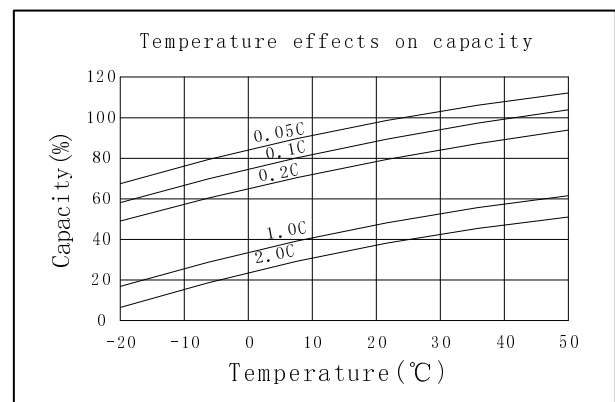
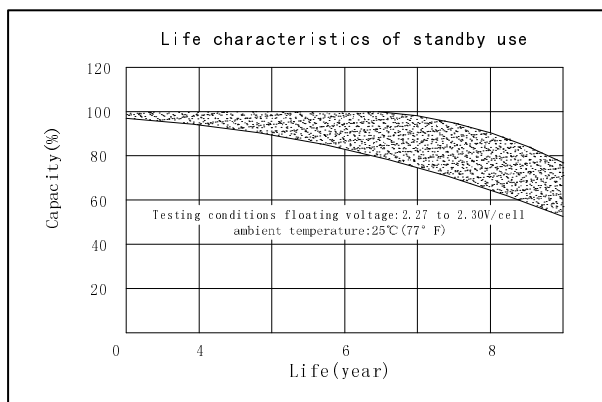
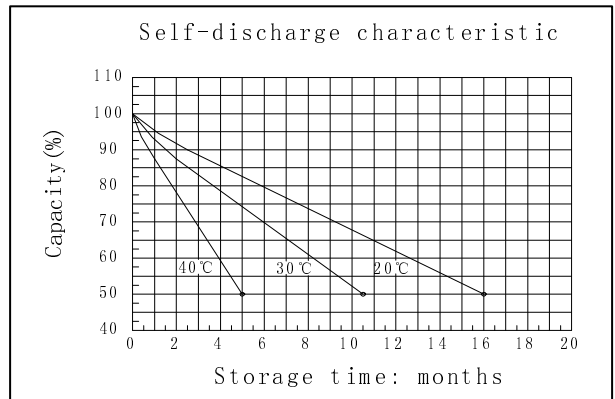
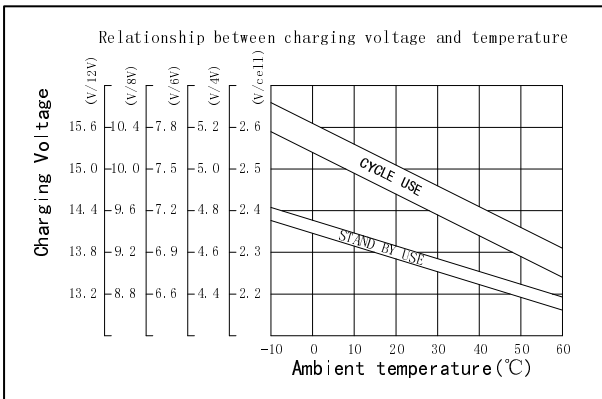
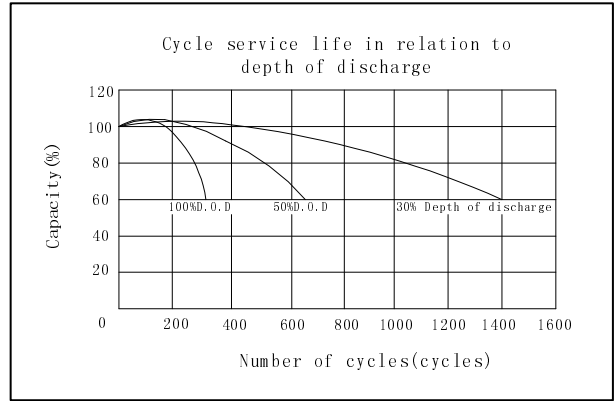
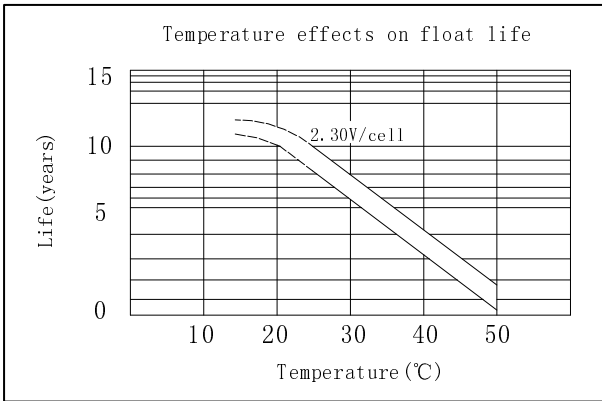
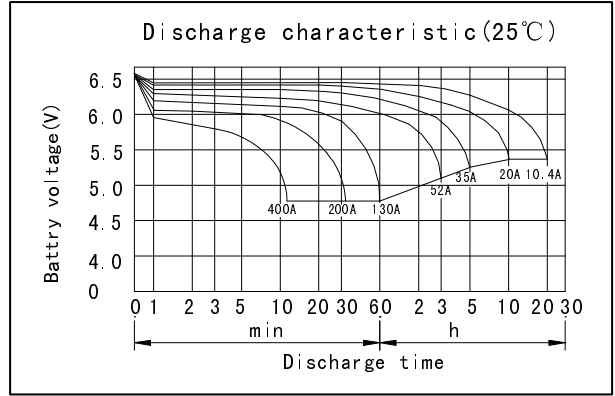
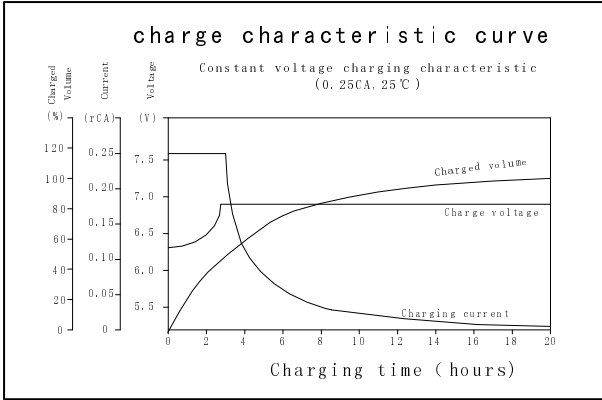

OREMA POWER CO., LTD

Add: Datang Industry Park Xinfeng Ganzhou City, Jiangxi Province, China

TEL: +86-0797-2299669 +86-0797- 2299553

FAX: +86-0797-2299553



www.oremabattery.com