

General Features

- Positive and negative plates in lead-calcium tin alloy.
- Superior energy density
- Operates at a low internal pressure.
- Gas Recombination.
- Low Self Discharge.
- Long Service Life.
- A recognized component of UL.
- Application specific designs.
- Six months shelf life at 20°C.
- Design life 10 years.



Dimensions

	Length	Width	Height	Total Height	Approx. Weight
<i>SI Units</i>	306mm	168mm	220mm	226mm	28.3Kg
<i>English Units</i>	12inch	6.61inch	8.66inch	8.9inch	62.4lbs

Performance Characteristics

- Nominal Voltage: 6V
- Number of cell: 3
- Nominal Capacity 77° F(25°C): 10 hour rate (20A, 5.25V) 200Ah
1 hour rate (128A, 4.8V) 128Ah
- Internal Resistance: Fully Charged battery 68° F(25°C) 3mΩ
- Self-Discharge: 3% of capacity declined per month at 20°C
- Operating Temperature Range: Discharge -20~60°C Charge -10~60°C Storage -20~60°C
- Max. Discharge Current 68° F(25°C): 1000A (5S)
- Short Circuit Current: 3200A
- Charge Methods: Constant Voltage Charge 68° F(25°C)
Cycle use: 7.25 ~ 7.45V Maximum charging current 50A
Standby use: 6.80 ~ 6.90V

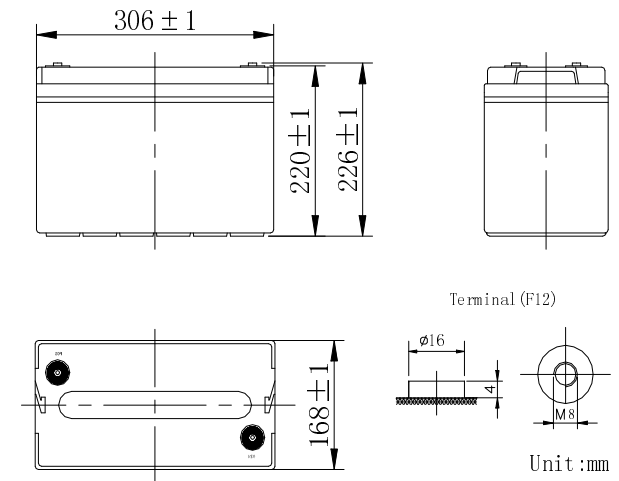



UN200-6X 6V200Ah

Rechargeable Products Sealed Lead Acid Battery

Discharge Data

Constant Current Discharge Data(Amperes at 25°C)

End Voltage Per cell/V	10min	15min	20min	25min	30min	35min	40min	45min	50min	55min	1h	1.5h	2h	2.5h	3h	4h	5h	6h	7h	8h	9h	10h	20h
1.60	405.0	335.0	275.0	234.0	205.0	185.0	170.0	158.0	147.0	137.0	128.0	95.0	75.7	63.2	54.2	43.8	37.5	32.2	28.4	25.3	22.5	20.5	10.4
1.65	389.0	323.0	266.0	227.0	199.0	180.0	165.0	154.0	144.0	134.0	126.0	93.0	74.0	62.0	53.2	43.0	36.6	31.7	28.0	25.0	22.3	20.4	10.4
1.70	372.0	310.0	256.0	219.0	192.0	174.0	160.0	149.0	140.0	131.0	123.0	90.5	72.0	60.5	52.0	42.0	35.8	31.1	27.5	24.6	22.0	20.2	10.3
1.75	353.0	296.0	245.0	210.0	185.0	168.0	154.0	144.0	136.0	127.0	120.0	88.0	70.0	59.0	50.8	41.0	35.0	30.5	27.0	24.2	21.7	20.0	10.2
1.80	332.0	280.0	233.0	200.0	177.0	161.0	147.0	138.0	131.0	123.0	116.0	85.0	67.8	57.3	49.5	39.8	34.1	29.8	26.4	23.7	21.3	19.7	10.1

Constant Power Discharge Data(Watts per cell at 25°C)

End Voltage Per cell/V	10min	15min	20min	25min	30min	35min	40min	45min	50min	55min	1h	1.5h	2h	2.5h	3h	4h	5h	6h	7h	8h	9h	10h	12h
1.60	695.0	590.0	495.0	422.0	375.0	335.0	303.0	280.0	258.0	245.0	235.0	175.0	140.0	116.0	103.3	84.5	72.0	62.5	53.4	47.4	42.3	38.8	32.7
1.65	670.0	570.0	479.0	409.0	374.0	325.0	294.0	272.0	251.0	239.0	230.0	171.5	137.5	114.0	101.6	83.3	71.1	61.8	52.8	46.9	41.9	38.5	32.5
1.70	643.0	548.0	462.0	395.0	362.0	314.0	284.0	263.0	243.0	233.0	225.0	167.5	134.5	111.6	99.6	81.8	70.0	60.9	52.1	46.3	41.4	38.1	32.2
1.75	614.0	524.0	443.0	380.0	349.0	302.0	274.0	254.0	235.0	226.0	219.0	162.5	131.0	108.8	97.3	80.0	68.7	59.5	51.3	45.6	40.9	37.7	31.9
1.80	583.0	498.0	422.0	363.0	334.0	289.0	263.0	244.0	226.0	218.0	212.0	157.0	127.2	105.5	94.5	78.0	67.2	58.8	50.4	44.8	40.3	37.2	31.5

